

Calculate the missing information using your knowledge of series and parallel circuits.

1.

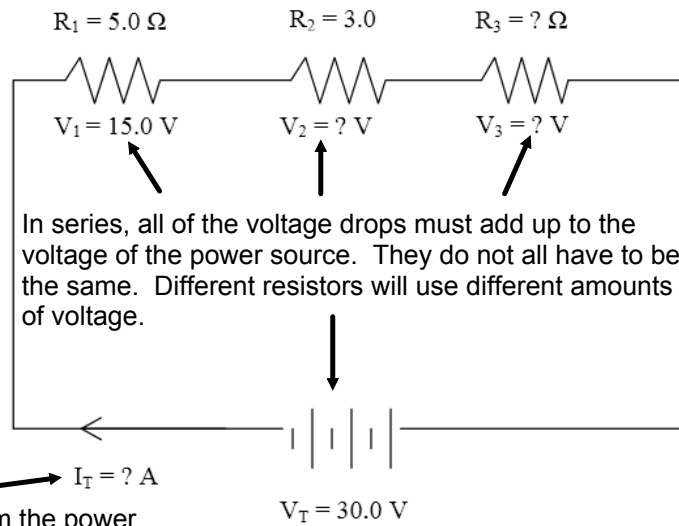

In series, all of the voltage drops must add up to the voltage of the power source. They do not all have to be the same. Different resistors will use different amounts of voltage.

In series the current from the power source goes through each resistor.

2.

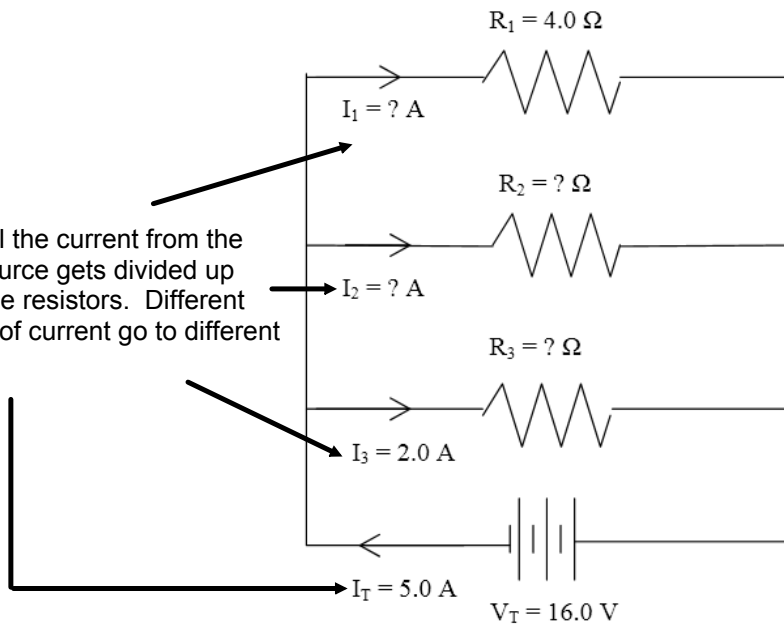

In parallel the current from the power source gets divided up among the resistors. Different amounts of current go to different resistors.

In parallel each resistor gets the same voltage as power source.

The next two problems combine the theory of series and parallel circuits.

3.

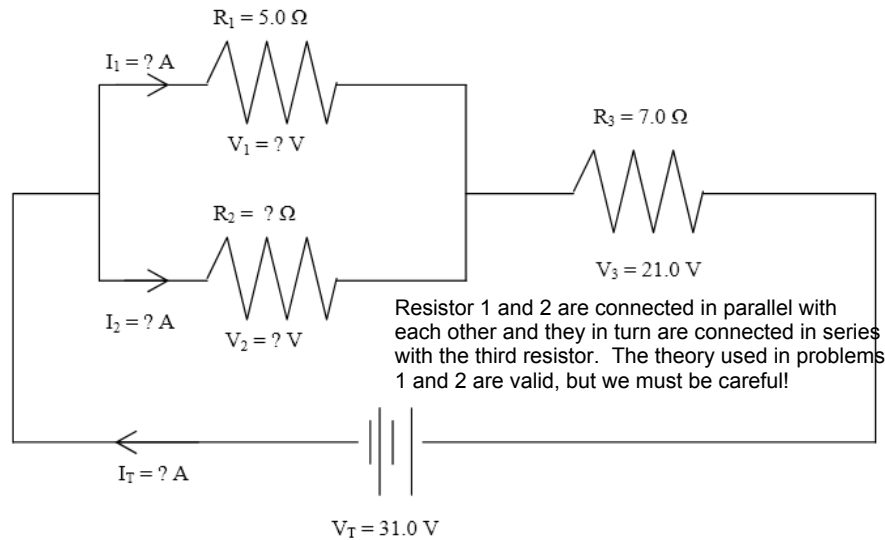

Follow the schematic carefully, the current from the power source divides up then recombines to go through the third resistor. The voltage available to the parallel section added with the third resistor must equal the power source. The voltage available to the parallel section applies to both resistors. So, in this example the third resistor has a voltage drop of 21 V. That leaves 10 V for the parallel section so both resistor #1 and #2 have a voltage drop of 10 V. Please note that all of the voltage drops do not have to add up to the voltage of the power source, but the sections in series do.

4.

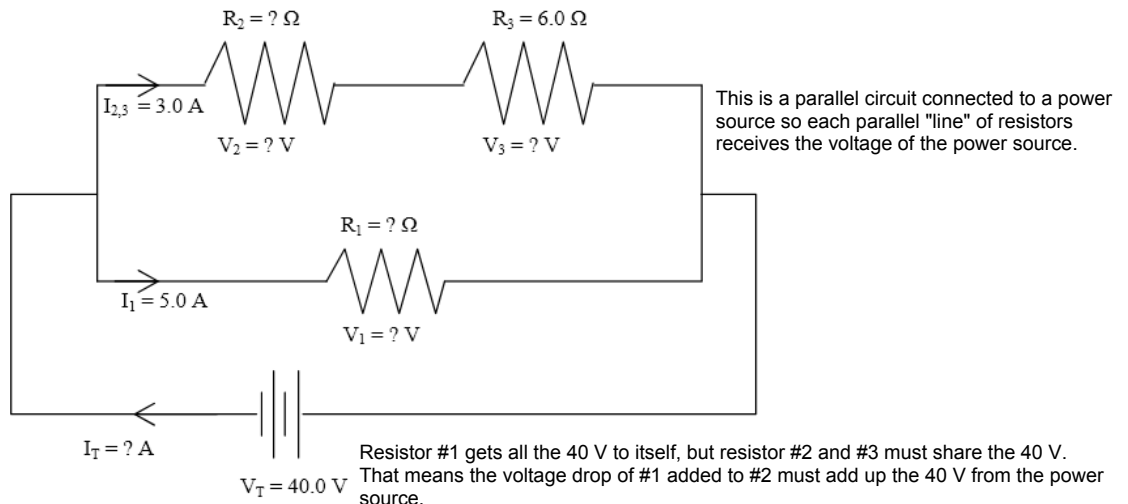

V-I-R Table for Schematic #1

Resistor #	V (V)	I (A)	R (Ω)
1			
2			
3			
Totals	$V_T =$	$I_T =$	$R_{eq} =$

These are called Voltage-Current-Resistance or V-I-R tables. They aid in organizing the information given in circuit schematic problems and solving for the unknown quantities.

Ohm's Law, $V = I \times R$, is obeyed for every resistor and for the circuit as a whole. In every row the voltage must equal the current multiplied by the resistance.

R_{eq} stands for *equivalent resistance*, it is the net resistance that determines how much current will be drawn from the power source (it is not always the sum of all the resistors so be careful - it is always $V_T \div I_T$.) Depending on how the resistors are connected it is possible to "fool" the battery into thinking there is less resistance than it seems!

Use these tables in combination with the actual diagram to fill in or calculate all the missing data. Pay very close attention to the type of circuit you are working with.

V-I-R Table for Schematic #2

Resistor #	V (V)	I (A)	R (Ω)
1			
2			
3			
Totals	$V_T =$	$I_T =$	$R_{eq} =$

V-I-R Table for Schematic #3

Resistor #	V (V)	I (A)	R (Ω)
1			
2			
3			
Totals	$V_T =$	$I_T =$	$R_{eq} =$

Look at V_1 and V_2 , they are the same because they are in parallel but their voltage adds with V_3 to give the total voltage of the power source.

V-I-R Table for Schematic #4

Resistor #	V (V)	I (A)	R (Ω)
1			
2			
3			
Totals	$V_T =$	$I_T =$	$R_{eq} =$

Here the power source supplies 40 V to each parallel "line" of resistors. Looking at the schematic, the top row must share that voltage because they are in series.