

Square Roots, Pythagorean Theorem, & Surface Area**Short Answer**

1. List all the whole numbers between 63 and 101 that are perfect squares.
2. Determine the value of $\sqrt{0.16}$.
3. Determine the value of $\sqrt{0.81}$.
4. Name the two whole numbers whose squares are closest to 23.5.
5. Determine the value of $\sqrt{77.2}$, to the nearest tenth.
6. This object is composed of a right triangular prism on top of a right rectangular prism. Determine the surface area of the object.

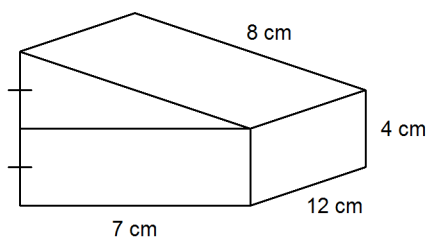

7. This object is composed of a cylinder of diameter 8 cm and height 14 cm on top of another cylinder of diameter 12 cm and height 6 cm. Determine the surface area of the object, to the nearest square centimetre.

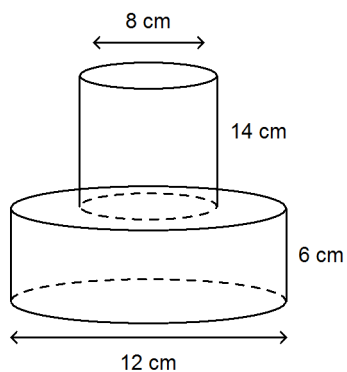

8. This composite object is made using centimetre cubes. Determine its surface area.

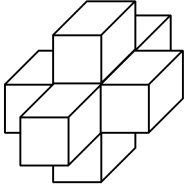

9. This object is composed of a cube on top of a right rectangular prism. Determine the surface area of the object.

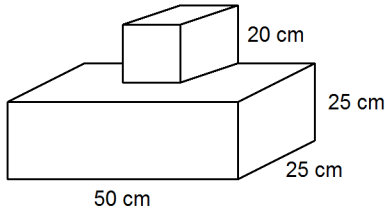

10. Determine the surface area of this composite object, to the nearest square centimetre. The cylinder has diameter 2 cm and height 3 cm. The prism has length 14 cm, width 7 cm, and height 7 cm.

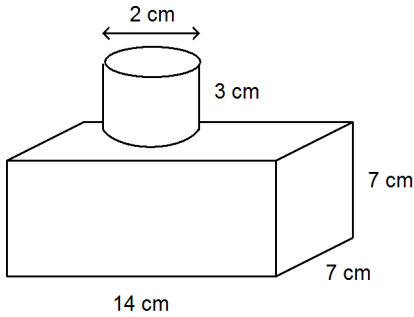

11. A barn is built in the shape of a right rectangular prism with a semi-circular roof. Determine the surface area of the barn. Give your answer to the nearest whole number.

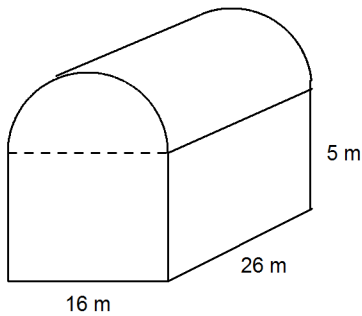

Square Roots, Pythagorean Theorem, & Surface Area Answer Section

SHORT ANSWER

1. 64, 81, 100
2. 0.4
3. 0.9
4. 4, 5
5. 8.8
6. 408 cm^2
7. 804 cm^2
8. The surface area of the object is 30 cm^2 .
9. The surface area of the composite object is 7850 cm^2 .
10. The surface area of the object is about 509 cm^2 .
11. The surface area of the barn is about 1275 m^2 .