

# Electrochemistry

For any two metals in an activity series, the more active metal is the more readily oxidized.

**Table 21.1**  
Activity Series of Metals, with Half-Reactions for Oxidation Process

	Element	Oxidation half-reactions
Most active and most easily oxidized ↓ Decreasing activity ↓ Least active and least easily oxidized	Lithium	$\text{Li}(s) \longrightarrow \text{Li}^+(aq) + e^-$
	Potassium	$\text{K}(s) \longrightarrow \text{K}^+(aq) + e^-$
	Barium	$\text{Ba}(s) \longrightarrow \text{Ba}^{2+}(aq) + 2e^-$
	Calcium	$\text{Ca}(s) \longrightarrow \text{Ca}^{2+}(aq) + 2e^-$
	Sodium	$\text{Na}(s) \longrightarrow \text{Na}^+(aq) + e^-$
	Magnesium	$\text{Mg}(s) \longrightarrow \text{Mg}^{2+}(aq) + 2e^-$
	Aluminum	$\text{Al}(s) \longrightarrow \text{Al}^{3+}(aq) + 3e^-$
	Zinc	$\text{Zn}(s) \longrightarrow \text{Zn}^{2+}(aq) + 2e^-$
	Iron	$\text{Fe}(s) \longrightarrow \text{Fe}^{2+}(aq) + 2e^-$
	Nickel	$\text{Ni}(s) \longrightarrow \text{Ni}^{2+}(aq) + 2e^-$
	Tin	$\text{Sn}(s) \longrightarrow \text{Sn}^{2+}(aq) + 2e^-$
	Lead	$\text{Pb}(s) \longrightarrow \text{Pb}^{2+}(aq) + 2e^-$
	Hydrogen*	$\text{H}_2(g) \longrightarrow 2\text{H}^+(aq) + 2e^-$
	Copper	$\text{Cu}(s) \longrightarrow \text{Cu}^{2+}(aq) + 2e^-$
	Mercury	$\text{Hg}(s) \longrightarrow \text{Hg}^{2+}(aq) + 2e^-$
	Silver	$\text{Ag}(s) \longrightarrow \text{Ag}^+(aq) + e^-$
	Gold	$\text{Au}(s) \longrightarrow \text{Au}^{3+}(aq) + 3e^-$



Example: zinc metal in a solution of copper (II) sulfate

↓  
oxid.

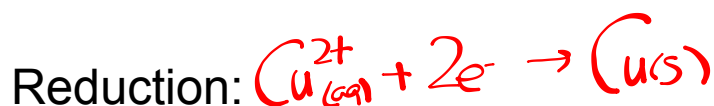
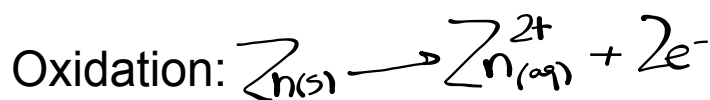

a500303 [RM] © www.visualphotos.com



a500303 [RM] © www.visualphotos.com



a500304 [RM] © www.visualphotos.com



**Electrochemical process** - any conversion between chemical energy and electrical.

- all involve redox reactions
- half reactions must be physically separated if reaction is to be used as a source of electrical energy
- an electrochemical cell is any device that converts between electrical energy and chemical energy

# Voltaic Cells

- electrochemical cells used to convert chemical energy into electrical energy
- electrical energy is produced in a voltaic cell by spontaneous redox reactions within the cell
- A half-cell is one part of a voltaic cell in which either oxidation or reduction occurs.
  - normally consists of a metal immersed in a solution of its ions
  - half-cells are connected by a salt bridge - a tube containing a strong electrolyte
- electrode - a conductor in a circuit that carries electrons to or from a substance other than a metal
  - anode** - the electrode at which the oxidation occurs (labeled the negative electrode because electrons are produced)
  - cathode** - the end at which reduction occurs (labeled the positive electrode because electrons are consumed)
- always remains balanced in terms of charge because of the salt bridge

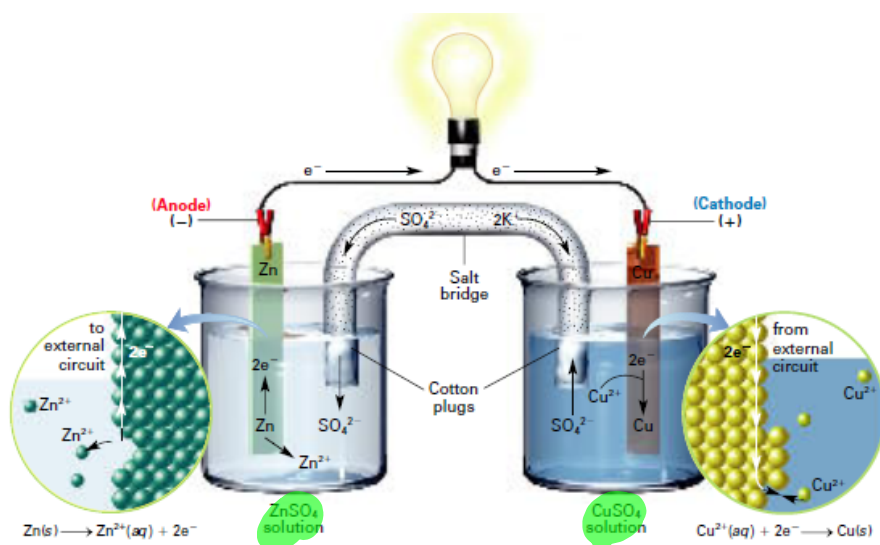

[http://www.youtube.com/watch?v=JuWS0d\\_1Ghg](http://www.youtube.com/watch?v=JuWS0d_1Ghg)



**How a Voltaic Cell Works** The electrochemical process that occurs in a zinc-copper voltaic cell can best be described in a number of steps. These steps actually occur at the same time.

1. Electrons are produced at the zinc rod according to the oxidation half-reaction.



Because it is oxidized, the zinc rod is the anode, or negative electrode.

2. The electrons leave the zinc anode and pass through the external circuit to the copper rod. (If a bulb is in the circuit, the electron flow will cause it to light. If a voltmeter is present, it will indicate a voltage.)
3. Electrons enter the copper rod and interact with copper ions in solution. There the following reduction half-reaction occurs.

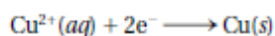

Because copper ions are reduced at the copper rod, the copper rod is the cathode, or positive electrode, in the voltaic cell.

4. To complete the circuit, both positive and negative ions move through the aqueous solutions via the salt bridge. The two half-reactions can be summed to show the overall cell reaction. Note that the electrons in the overall reaction must cancel.

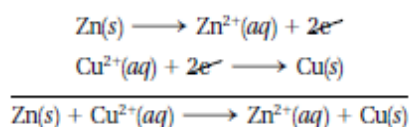

## Using Voltaic Cells as Energy Sources

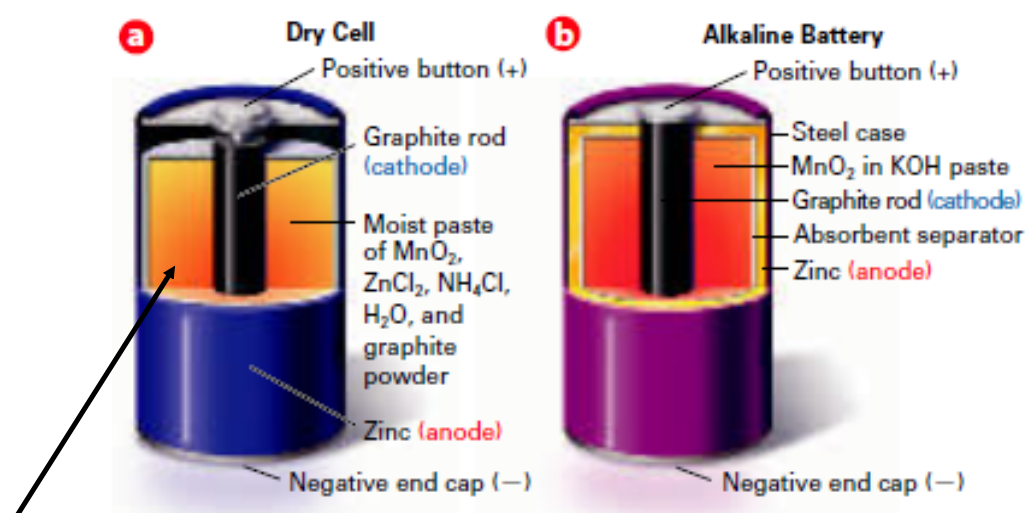

electrolyte is a paste

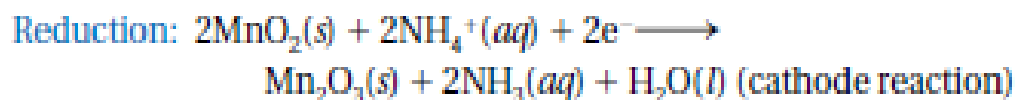

## Lead Storage Batteries



A **battery** is a group of cells connected together.

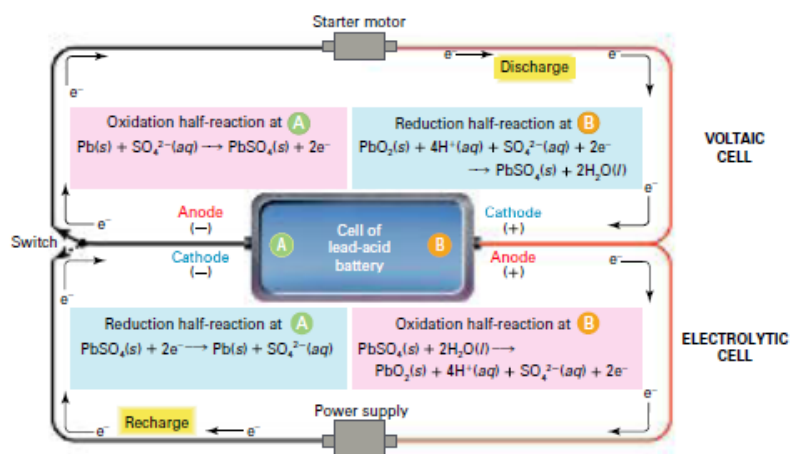
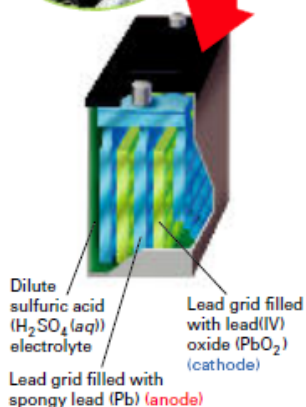



# Fuel Cells

Voltaic cells in which a fuel substance undergoes oxidation and from which electrical energy is continuously obtained.

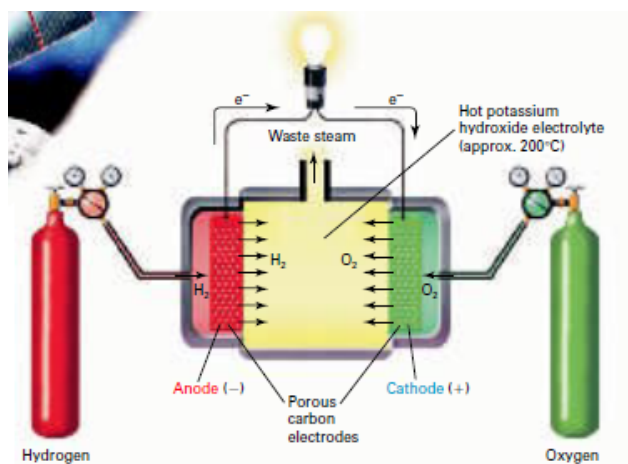

# Homework

p. 670 #1-8